

Axial Belt-Drive Upblast Exhaust Ventilator



Designed for use in industrial and commercial buildings such as warehouses, manufacturing facilities, foundries, and laboratories. Housing is constructed of heavy gauge galvanized steel. The windband is removable for easy inspection. Lifting lugs are provided.

- Maximum inlet air temperature: 120° F
- UL/cUL 705 Listed for Power Ventilators
- Air handling quality bearings meet minimum of L10-100,000 hours
- Sealed pillow block bearings



Dayton Electric Mfg. Co. certifies that the ventilators shown herein are licensed to bear the AMCA seal. The ratings shown are based on tests and procedures performed in accordance with AMCA Publication 211 and AMCA Publication 311 and comply with the requirements of the AMCA Certified Ratings Program.

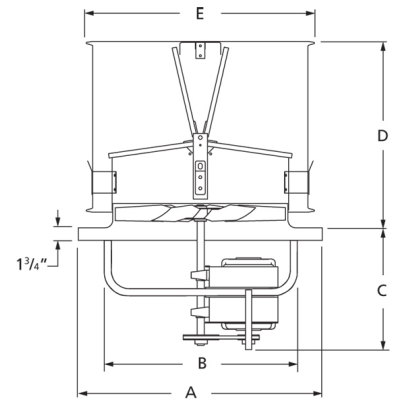

A	B	C	D	E
36 3/8 in	28 3/8 in	16 in	26 in	31 1/8 in

Performance Characteristics

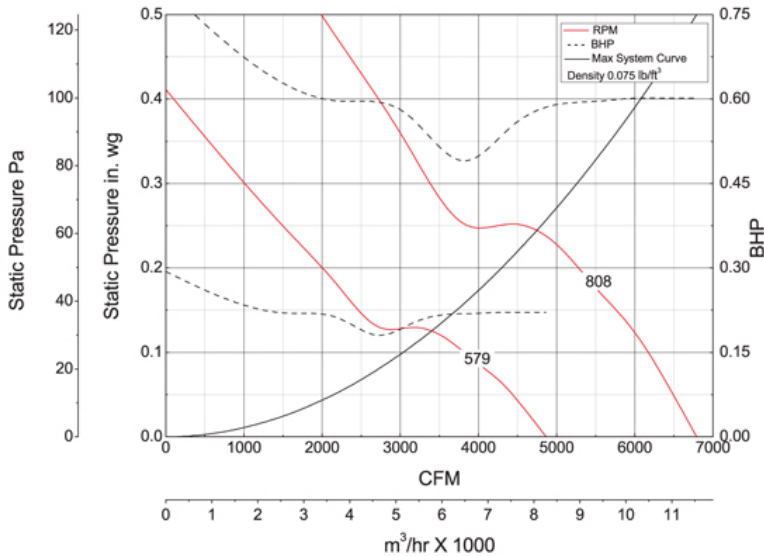

Construction Features

Impeller Diameter (Typ.)	24 in
Impeller Type	Propeller
Impeller Material	Steel
Max Inlet Temp	120 °F
Bearing Type	Sealed Pillow Block
Drive Package Description	Drives Packaged Separately
Warranty Length	1 Year

Motor Information

Motor Item Number	31TT08
Voltage	208-230/460
Hertz (Cycle)	60 Hz
Motor Phase	3
Motor Enclosure	Open Drip Proof
RPM	1,725 rpm
Full Load Amps	1.7-1.7/0.85

Other Components

Component	Description	Item #
Fan Description	Exhaust Fan	—
Belt	A28 (QTY: 1)	6A140
Driver Sheave	1VP3458	5UHR1
Driven Sheave	AK69	6YRD3
Driven Bushing	QT34	5UJA2

Air & Sound Performance

Motor HP	Max BHP	Fan RPM	CFM @	0.000" SP	0.125" SP
1/2	0.60	808	CFM	6791	5985
			Sones	18.2	16.4

Performance certified is for installation type A: Free inlet, Free outlet. Power rating (BHP) does not include transmission losses. Performance ratings do not include the effects of appurtenances (accessories). The sound ratings shown are loudness values in fan sones at 5 ft. (1.5 m) in a hemispherical free field calculated per AMCA Standard 301. Values shown are for installation type A: Free inlet hemispherical sone levels.

Operating Range of Drive Package

Turns Open	FRPM @ 0 TO	FRPM @ 1/2 TO	FRPM @ 1 TO	FRPM @ 1 1/2 TO	FRPM @ 2 TO	FRPM @ 2 1/2 TO	FRPM @ 3 TO	FRPM @ 3 1/2 TO	FRPM @ 4 TO	FRPM @ 4 1/2 TO	FRPM @ 5 TO
Approx. FRPM	808	792	765	739	712	685	659	632	605	579	—